

# NATIONAL RADIO NEWS



## IN THIS ISSUE

How to Start A Spare-Time Service Business

How Circuit Diagrams are Used in Servicing

Alumni Association News

DEC.-JAN.  
1946-1947

Vol. 12  
No. 6



# A Merry Christmas

Christmas is a season of gaiety. We enjoy the good cheer, the friendly smiles of strangers. It is the season for kindling the flame of good will in the heart.

For those less fortunate our sympathies are thoroughly aroused. We enjoy the privilege of giving. We appreciate more deeply the warmth of each other's handshake. We are moved by a spirit of good cheer, of kindness, understanding.

We live for a few days in a world as it should be.

It is a great satisfaction at this season of the year to have a little friendly magazine of this kind which is all our own—yours and ours—through which we have this opportunity to wish you, on behalf of our entire staff, a very Merry Christmas and the hope that the New Year will bring you new advancement, good health and happiness in abundance.

J. E. SMITH, President.

E. R. HAAS, Vice-President.



# How To Start A Spare-Time Service Business

By WILLIAM FRANKLIN COOK

NRI Supervisor of Instruction Material

*Some practical suggestions which will be very helpful to the beginner in Radio Servicing.*



Wm. Franklin Cook

**T**HIS article is intended for the man who wants to start a real business in spare-time servicing. If you look on radio more or less as a hobby, perhaps intending to service a few sets when you feel like it, but with no intention of carrying your servicing any further than that, you need no business information. But if you intend to make spare-time work a steady source of income—with an eye, perhaps, to an eventual full-time servicing business—you must learn a few simple business facts.



Manual Flores, of San Antonio, Texas, at work. Several years ago he started his radio business on a spare-time basis. At that time he averaged \$25 a week profit. His business has grown into a full-time occupation, with more radio work than he and his assistants can handle.

This article gives you some of the information you need. It shows you what you need in the way of training and equipment to get started, how to get business, and how to handle it.

## Are You Ready?

Before you even consider starting a service business, you should ask yourself one question—"Do I have enough technical knowledge to be a serviceman?"

In the beginning, in starting your spare-time service business *be careful in selecting your customers*. Do work for your relatives, friends, and acquaintances—people with whom you can be candid about your abilities.

Don't be afraid to tell them if the job is too much for you. Since they know you, they will be ready to make allowances for the fact that you may not have yet completed your training. Then, if you find the job is more than you can handle, your servicing reputation will not be harmed; your friends will realize that you will be able to do the job later on when you have progressed further in your studies.

Remember, though, that you can't expect a stranger to be as understanding. That's why you should do your first work for people who know you. Be sure you can handle every job you do accept, and do the best work you can on each one. In that way, you'll get off on the right foot, and enjoy a good reputation among your customers.

## Getting Practical Experience

Before you can advance very far as a serviceman, you must have some practical experience to round out your training in theory.

There is a vast difference between reading about how to make a test and actually making the test. Even when you know all the theory involved, the only way you can locate and repair a defect with professional speed is to have done it several times before.

One way you may get the necessary experience is to take any servicing job you can get—do the best you can on it—and depend on some friendly and experienced serviceman to rescue you if the job proves too tough. This is a possible way, but not a good one. For one thing, few servicemen are willing to help a potential competitor. And for another, the practice you get will tend to be concentrated on the more common defects—you might have to service hundreds of sets before you get the all-around experience a real Radiotrician needs.

However, there is no need for you to try this difficult method of getting experience. The NRI Practical Training Plan will give you practical servicing experience on an actual receiver. You learn exactly how to make professional tests to track down all kinds of defects—and you learn this by doing them with your own hands on a real set. This plan is explained fully in Job Sheet 25, which is sent to NRI students when the graded answers to Lesson 23 are returned.

We do not recommend that you try to get experience by starting work in some radio shop as an apprentice. This is not a good idea for two reasons: (1) you are not apt to learn much, and (2) the starting pay will be very small. If you enter a shop when you are still only part way through your NRI training, you will undoubtedly be expected to follow the service methods used by the shop owner. In many cases, these will not be nearly as good as the methods you will learn in your NRI Course. In fact, a student very often retards his progress rather

than advances it if he attempts to get experience in a shop. Even if the shop owner is himself competent, he will seldom have time to teach you; remember, he is working for a living, and his time means money to him. He will expect you to assist him, to change parts, and in general to do the "dirty work" of servicing. You will be far better off to get your technical knowledge from your Course and gain experience from the NRI Practical Training Plan. Also, you will probably make far more in your own spare-time business than you could working as an apprentice for someone else.

Of course, these words of caution about starting a servicing business apply mainly to the beginner in Radio servicing. If you study your Course carefully, it will not be long before you'll be able to service almost any job you may happen to get. When you have progressed that far, there will be no reason for you to lack confidence in your ability as a serviceman.

Whether you want to start your business at once or wait until you have had more training, you are ready to begin planning your spare-time business after you have completed about 20 lessons.

### What Equipment You Need

When you go into spare-time servicing as a business, first of all you will need a shop or place in which to work. Information on planning the Service bench and shop is given in Job Sheet 26, sent to NRI students when the graded answers to

lesson 24 are returned.

In addition to a bench and shop, you will need suitable test equipment.

**Test Instruments.** The basic servicing instruments you need at the start are a multimeter and a signal generator.

If you can afford it, a tube tester will also prove very handy. However, it may be possible for you to take tubes to some store to have them tested if you do not wish to invest in a tube tester at once. The NRI Tester which you build in your second Experimental Kit will be an adequate, serviceable test instrument for



Stephen J. Petruff, of Miami, Fla., testing a receiver in his radio shop. Through spare-time earnings, Mr. Petruff built up an array of stock and equipment amounting to \$500 in value. Eventually, he opened a full-time Radio Store. Before finishing the Course, he earned as much as \$10 to \$15 in one week, servicing sets in spare time.

your bench work at first. However, since it is not easily carried, you will probably want to buy a commercial instrument in a carrying case before very long.

A multimeter, signal generator, and tube tester are all that you actually need when you start servicing. However, you should get a signal tracer as soon as your servicing profits will pay for it, because a tracer will speed up your work considerably.

**Basic Stock.** You should have a certain amount of replacement stock in your shop. It is, of course, possible to service on a "hand-to-mouth" basis, buying parts only when you need them; however, you can complete repairs faster if you have a few of the most frequently used parts in your shop and replace them as you use them up.

(Plan to invest the profit of your first jobs in equipment and supplies, and you will be enabled to earn greater profits on later jobs.)

#### Basic Stock of Radio Supplies

**Paper Condensers**—six each of 600-volt condensers in these capacities: .001; .002; .005; .01; .02; .05; .10; .25; .50 (all capacities in mfd).

**Tubular Electrolytics**—two 20-20 mfd., 150-volt with separate leads; one 10 to 100 mfd., 25-volt; two each of 450-volt condensers in these capacities: 8, 20, and 40 mfd.

**Resistors**—one kit each of ½-watt and 1-watt carbon resistors (these kits contain the sizes used most often).

**Volume Controls**—one kit of assorted controls.

**Output Transformers**—one universal; one a.c.-d.c. (designed to match 50L6 output stage to 6-ohm speaker).

**Tubes**—See below.

**Miscellaneous**—roll of rosin core solder; roll of friction tape; assortment of spaghetti (varnished cambric insulating tubing); tube of speaker cement; can of solvent; pilot lamps.

Besides these parts, you will need a fair assortment of tubes. The kind and quantity for you to get will depend to some extent upon your location. That is, if a.c.-d.c. sets are the most common types in use around you, your tube assortment should feature tubes with 12, 25, 35, and 50-volt filament voltages. Or, if you are in a farm district, you may find that the 2-volt and 1.4-volt battery tubes are the ones most commonly used. If there is a wholesaler in your town, he can probably recommend a good basic tube assortment for you, based on his experience with other servicemen. If not, you will learn rather soon what kinds of tubes you need

most. If there is no wholesaler near you, write to a mail-order wholesale house or directly to a tube manufacturer and ask what tubes are recommended for starting a shop in your locality.

The preceding assortment gives you only the basic supplies you need to start a part-time business. Get other parts from your wholesaler or wholesale mail-order house only as you need them; do not stock other parts until experience



Joseph A. Dubanoski, Manchester, Conn., at work on a receiver. He reports earnings of from \$5 to \$20 a week in spare-time servicing. Before he had graduated, he earned enough to pay for the NRI Course, and during a twelve month period, profits were \$500. Dubanoski says that many of his customers want to buy new radios from him, since they have confidence in his knowing radio.

shows that you need them often enough to justify it. Re-order stock items frequently enough so that you are never completely out of any one of them (or, in the case of "one-of-a-kind" items, as soon as you use the one you have).

If you are quite a distance from a wholesaler, or intend to buy exclusively from mail-order

houses, we suggest you increase this basic stock by getting a larger and more varied stock of electrolytic condensers and 1/2-watt, 1-watt, and 10-watt resistors. (Remember, though, that electrolytic condensers have a *shelf* life of only about a year, so don't buy so many that you will have to throw them away.) Eventually, you might also stock two 5-inch PM speakers, and perhaps two universal replacement power transformers with 6.3-volt filament windings. Get one with a 70-ma. high voltage winding rating for 6 or 7 tube sets, and one with a 90-ma. high voltage winding rating for 8 or 9 tube sets. (These are for emergency use only; you should use an exact duplicate replacement for a power transformer when you can). Finally, you might stock two 456-kc. standard replacement i.f. transformers. Get an input and an output transformer or a pair of general purpose transformers.

Remember—stock other materials only if you really need them. You are a serviceman, not a supply house; don't tie up too much of your money in stock.

**Where to Buy.** It is no longer necessary for the serviceman to deal directly with numerous radio manufacturers to get a supply of parts. Today, you can deal with the local wholesale supply houses or with distributors that cover your area, or you can order from the mail-order supply houses. The names and addresses of wholesale supply houses and of parts distributors in your locality can be found in your local telephone book. Look in the classified section. If you do not know the names and addresses of the large mail-order supply houses, we will be glad to send you a list of them if you send in your request to NRI.

By dealing with a local wholesaler or with a mail-order house, you will automatically get a trade discount.

**Business Supplies.** A neat, well printed business letterhead is one of the first things you should get when you start a business. At the beginning, you won't need many—250 will last you a long time unless you use them also for submitting bills to your customers. If there is a job printer near you, by all means let him make up your letterheads, if not, you can buy them by mail from one of the firms that advertise in magazines or from mail-order stores like Sears, Roebuck or Montgomery Ward. Tube companies often offer, at very reasonable rates, business stationery imprinted with your name and their ad.

You can also get other business supplies from tube companies. These include business cards, billheads, stickers to put on tubes you have tested, price cards, repair tickets, prospect cards, service order pads, and record books.

These are usually of good quality and very in-

expensive. Of course, all carry an ad for the company that supplies them to you, so it is best for you to get such supplies from the company whose tubes you use.

Your wholesaler probably has a catalog of the sales aids available from different tube manufacturers, or you can secure such catalogs by writing directly to the manufacturers. We suggest you get one of the catalogs and order one or more sales aids when you have definitely put yourself in a position to merchandise tubes. Remember, however, that you do not need everything shown in the catalog. In fact, printed stationery and business cards and perhaps billheads, are about all you need at the start. Later, you may find some of the other material useful.

**Transportation.** You should have a car or truck, or the use of one, to pick up and deliver sets. Sometimes it is possible to walk or use public transportation to make your service calls, but usually you have to carry too much equipment to make this practical. If you do not have a car, see if you can arrange with someone who has a car to take you to and from your calls.

**Telephone.** You should have telephone service in your shop. Most telephone companies insist that you have a business phone when you run a business, even in your own home. A business phone usually costs a little more than a private phone, but you have the advantage of being listed in the classified section of the phone book.

#### How To Get Business

One of the first things you should do is to give your business a name. Naturally, the name should identify your business as a *radio repair shop*: for this reason, we suggest you keep away from such names as "Electronics Laboratory"—particularly since you are not starting a large, elaborate shop, but only a spare-time business. Keep the name simple. You might use something like: "Bluffton Radio Repair Shop"; "Jones Radio Fix-It Shop"; "Uptown Radio Service Shop"; "Sam the Radio Man"; or some other name that shows what your business is.

**Should You Advertise?** Generally speaking, your best single ad is a satisfied customer. A man for whom you have done a good job is very apt to recommend you to his friends. A personal recommendation of that kind is almost sure to get you business. Since you will have a business phone, you will, as we said, automatically be listed in the classified section of your telephone book as a radio serviceman. This classified section is a real business-getter for servicemen, because it is the first place most people turn to when they want service. Just being listed there is helpful, but you will probably get considerably more business if you take at least a small display ad in that section. (The telephone company will be glad to help you write it.) Other

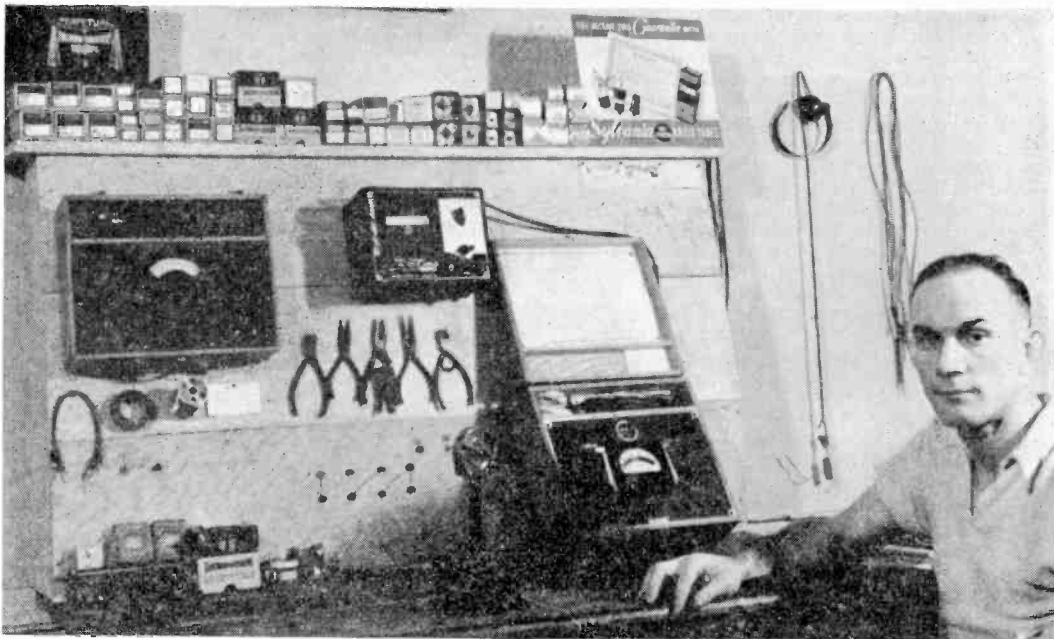

James F. Barton, who lives in Greer, S. Carolina, and his service bench. Just six weeks after enrolling, he made extra money checking tubes, erecting antennas, and other easy jobs like these. He made enough money in spare time to buy a tube checker, analyzer, and typewriter, besides paying for the NRI Course before his graduation. In his first year after graduation, he made more than \$500 in spare-time work.

forms of advertising are something you should consider only after you have made a fairly good start. You might experiment with circulars and direct mail advertising to find out whether they are profitable for you. When you are just starting out, or when you are entering a new territory, you may find that a free-inspection offer will bring results. These offers can be printed on post cards and mailed to the people near your shop, or can be distributed from door to door. (If you distribute advertising matter from door-to-door, don't put it in the mail boxes. It is illegal for anyone but the postman to put anything in these boxes.) If you make such a free offer, be sure to limit it to a brief period—say two weeks or a month. Remember, it is purely an introductory offer; we do not advise you to conduct free inspections as a regular thing. If you are a good salesman, you may find it profitable to make a personal canvass of the neighborhood near your shop. If you attempt this, be sure to have a short sales talk prepared in advance; introduce yourself, say that you are starting a radio servicing business in the vicinity, and ask that you be called to fix the radio when it goes out of order. Be sure to leave a business card as a reminder of your name and address, since you will seldom get business at the moment you call. If the prospect will permit you to do so, place your card inside the back of the set

where he can find it when the set needs servicing. Choose your canvassing time carefully; don't call around meal times, or at any time that the prospect seems to have company.

If you are not the salesman type and find door-to-door canvassing difficult, don't attempt it. A poor impression caused by a stumbling sales talk can do you more harm than good, since it is apt to make a prospect feel that you might do an equally poor job on his radio. Of course, it is no reflection upon you of you find it difficult to meet the public; that is true of a great many technical men. If you are one of them, you will be wise to start building up your business through mail advertising instead.

Your personal appearance is one thing you must always keep in mind when you are in business, whether or not you use door-to-door canvassing as part of your business-getting methods. People very often accept you at your own valuation. Look and dress like a back-alley mechanic, and that is what people will consider you to be; have the neat, clean appearance of a successful business man, and you'll be accepted as such. Don't overdress, however. Wear a plain business suit outside the shop. To protect your clothes, wear a shop coat or jacket when you are at the bench. Good manners are just as important as a good

appearance. If you feel ill-tempered and out of sorts, be careful not to let your customers know it. Be courteous always; never attempt to be high-hat with a customer; never argue with one. It is unprofitable to win an argument if it loses you a customer. On the other hand, you'll do well not to be too much of a "glad-hander"—many people resent that just as much as they resent surliness. The appearance of your shop is also something to consider. Some, at least, of your customers will see it from time to time, and you should be careful to have it in as good condition as possible. A neat, orderly shop does much to prejudice a customer in your favor and make him consider you a real professional.

#### How To Handle Business

There are two general ways of handling a spare-time service business. One is to have the customers deliver the set to your shop and pick it up when it is finished. This is an ideal system, but you will seldom get the customers to do it except on midgeet or portable receivers.

More usually, you will pick up the set at the home of the customer; take it to your shop; repair it; and then return it to the customer. When the repair to be made is slight—the replacement of a tube or some other minor repair—you can do the work in the customer's home. But if the job requires much work, by all means take the set to your shop unless the distance between the shop and the location of the receiver is too great. It is difficult to make any major repairs in the customer's home, as you can well imagine.

If you are servicing at night after spending a day on a regular job, you will have to budget your time carefully to get much done. When you have several jobs to do at a time, try to arrange things so that you pick up sets one night, repair them the next, and return them the third. This will enable you to do a much greater volume of business than you can handle if you bring each set back to the shop, repair it, and return it before you go on to another one. You should have someone (a relative, perhaps) in your shop to take calls for you while you are out picking up and delivering sets. Whoever does this for you should be courteous—remember, most of your customers will make their first contact with your business over the telephone. If the impression made is unfavorable, very likely the prospect will call someone else. The person answering the phone should find out where the set is, the nature of the complaint, the make, the model number (if the customer knows it—most do not), and when it will be convenient for you to check the set. If possible, a definite appointment should be made, or at least a time should be set when you can call back to make the appointment yourself.

When you are out picking up or delivering sets, call your shop from time to time to see if any

service calls have come in during your absence. Use a public phone to do so—not a customer's. Although most customers will allow you to use the phone if you ask, many of them do not like it. Better use a nickel and save a customer.

Of course, what we said about courtesy in answering phone calls applies to you as well as to anyone who may answer your phone in your absence. You will do well to develop a good "telephone voice." Have two or three friends criticize the way you speak over the phone, and correct the faults they agree on. Be sure your voice is clear and distinct; if people often ask you to repeat something you have just said over the phone, train yourself to speak more clearly.

#### Guaranteeing Your Work

Servicemen differ in the guarantees they give their customers. A few don't guarantee anything unless the customer insists on it. Most voluntarily guarantee their own work (but not the whole set) for a short period—usually ninety days. Others guarantee the whole set for thirty, sixty, or ninety days.

Legally, you are not forced to make any guarantee, but making one is often a good sales feature. Many customers have had unhappy experiences with sets that were repaired one day and broke down the next. The fact that you guarantee your work helps give such customers more faith in you.

What you do about a guarantee will depend at first on how much you have learned about fixing radios. It would be foolish for you to guarantee the whole radio until you have learned how to spot parts that are apt to become defective soon. Once you have learned to do so—in other words, when you have become a professional serviceman—you would do well to guarantee the whole set rather than just the part you work on. There are several reasons for giving a complete guarantee instead of just a partial one. For one thing, a customer almost invariably assumes that any defect that occurs in a radio after you have serviced it is your fault. If the defect is not your fault, and you refuse to repair it free, you will probably lose a customer. On the other hand, if you say the defect is not your fault and repair it anyway, the customer will believe that you must have been wrong or you would not have repaired it. You can't win in either case.

However, if you guarantee the whole receiver, the customer usually doesn't care whether the defect is your fault or not. He knows that you will repair it anyway, and, as long as you do so promptly, he will have no hard feelings toward you. However, you should always be careful to point out that the defect was not caused by your work, but by some part that proved defective without any previous indication that it was going to.





Spare-time radio servicing can lead to many interesting jobs. Servicing radio-phonograph combinations, such as the one shown above, is one.

You should make such an over-all guarantee only if the customer allows you to make all necessary repairs to the set. This means: (1) that he allows you to replace any part that seems likely to break down within the guarantee period, and (2) that no other serviceman is allowed to work on the set during the guarantee period. Naturally, the customer will be expected to pay more to have you check the whole receiver for actual or possible defects than to have you fix just the part that is causing trouble at the moment.

Unfortunately, many customers are unwilling to

spend more than is absolutely necessary to get the radio playing again. You should attempt to convince such a customer that he will be better off in the long run to allow you to check the radio thoroughly; in fact, you will do well to give some time and thought to working up a sales talk on this point. If the customer cannot be convinced, all you can afford to do is guarantee the work you have done. Never guarantee the whole radio in such a case—you will very often lose money by doing so. Only the most unreasonable customer would expect you to guarantee a whole set without checking it. Of course, how

many "call-backs" you have on a job depends chiefly on how well you do the job in the first place; you should not give any guarantee, except on your own work, until you have had enough training and experience to be an accomplished serviceman.

When you do guarantee a set, make it clear to the customer that your guarantee does not include tubes. There is no way for you to know how long a tube will last, so you will just be losing money if you do guarantee them. However, you can point out to the customer that new tubes themselves carry a guarantee—usually for ninety days.

### Keeping Records

There are three kinds of records you should keep as a spare-time business man. You should have a record of your income and expenses, a record of the work you have done, and a record of your customers. We'll discuss each of these in order.

**Financial Records.** You need a record of the finances of your business—its income and its expenses—both so that you can make out your income tax reports properly and so that you will know how much money you are making from your business. Right now, when you are just starting a servicing business, this record can be very simple. You can keep it in any notebook you happen to have, or you can buy a journal-ruled account or "cash" book in any five and ten cent store. Head one page "Income," head another "Expenses," and make suitable entries on the pages each time you receive income or incur expenses. For example, each time you are paid

for repairing a set, enter the amount you receive for the job on the page headed "Income." At the same time, enter any amount you pay for parts on the page marked "Expenses." Of course, you should date each entry and make some note of what it is for—"Parts," "Rent," "Received from Mr. Jones," etc. Just be sure you enter *all* income and *all* expenses connected with this business on these pages, and you will have an adequate record as far as your income taxes are concerned.

A simple bookkeeping system of this kind is good enough at the start. Later you will probably want to keep more detailed records that will show you the same facts, but present them in a form that is more convenient when you want to analyze the operation of your business.

**Job Records.** You will want to keep a record of each job you do. The easiest way to do this is to make a carbon copy of each bill you submit to a customer. Present the original to the customer, and retain the carbon for your file. On the back of the copy you keep, note the cost to you of the parts used and the number of hours you worked. *Do not put this information on the customer's bill*, however. Keep all carbon copies in some convenient place where you can get at them when you want them.

**Customer Records.** Finally, you should keep a record of your customers. The regular 3" by 5" file card, sold by all stationers and five and ten cent stores, is fine for making such a record. List on the card the name and address of the customer, his phone number, the date of your first call, the make, year, and model number of his set, the type of set (a.c., a.c.-d.c., d.c., battery, portable, auto), the kind of batteries used in it, the tubes used in it, and the type of antenna used with it. List the tubes in some standard fashion that will show you not only what they are, but where they are placed in the set. If you have a diagram and other service information for this particular receiver, it will be unnecessary for you to list tubes; in this case, note on the card that you have the diagram.

Make up a card like this for each of your customers; if a customer has more than one set, make up a card for each set. This file will prove valuable to you in several ways. For one thing, such a record of your customers will be handy if you decide to use mail advertising. Furthermore, when you receive a repeat call from a customer, you will be able to find out from your records what set he has, what tubes are in it, and what previous defects it has had. You will then be better prepared to service the set when you arrive at the customer's home, or at least better equipped to estimate what is the matter with it.



Here is a good example of how a spare-time Radio business may be started in the home. Floyd Haskins of West De Pere, Wis. turned a roll top desk into a work bench. A good start. Now, besides working in a Radio and Appliance store in a nearby city, he has built up a good sized Radio business in his home.

There is one rule you must always follow if your business is to grow. You must keep your business finances separate from your personal finances. If you simply pocket everything you receive in payment for your services, you will have a source of income, but you will not have a business.

The right way to treat a business is to consider that you are working for it, just as if it were owned by someone else. This means that your salary must be listed as a business expense like rent, replacement of test equipment, upkeep of your car, etc. However, to get your business off to a good start, you should charge only a very small salary for yourself at the beginning. In fact, you will do well not to draw any salary at all for a while. Build up a cash reserve.

Such a cash reserve is absolutely necessary to a business. It represents money that can be used to meet unexpected expenses and to buy parts and equipment you will need for expansion. The more money you allow the cash reserve to accumulate, the better the financial health of your business will be.

When the reserve is large enough to take care of anything you are apt to use it for, draw a reasonable salary from the business each month. Make sure you do not draw so much that the business loses money in any month. This will allow the cash reserve to keep growing. From time



Mr. C. F. Smith, Sr., trained by NRI, finds spare-time radio servicing is profitable in his home in Portsmouth, Va.

to time—say every three months—you can withdraw from this reserve any amount in excess of what you feel the reserve should be. This you can consider to be your profit on the business. One of the best ways of separating your business finances from your personal finances is to establish a separate bank account for your business. If you do this, deposit every cent earned by the business in the bank, and pay all bills (including your salary) by check. This method will both remove temptation to spend the business money for your personal expenses and also give you a record (by way of your check stubs) on the income and expenses of the business. Of course, you will sometimes have to pay cash for small bills. In this case pay the bills out of your own pocket, and keep a record of the total. When the total becomes a few dollars, pay yourself by check from the bank account.

**Looking Ahead.** You have now learned the basic steps to take in setting up a spare-time business. The rest depends on you. Gradually, you will learn and profit by experience. The important part is getting started properly. Once that's accomplished, future success is not as uncertain as it would be without forethought and preparation.



Spare-time work includes servicing portables, such as the one carried by this young lady.

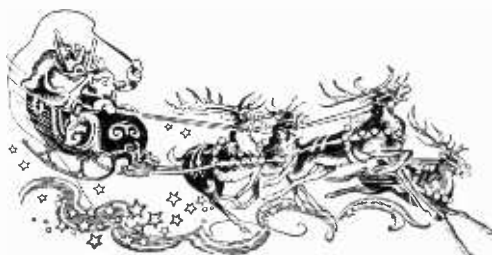

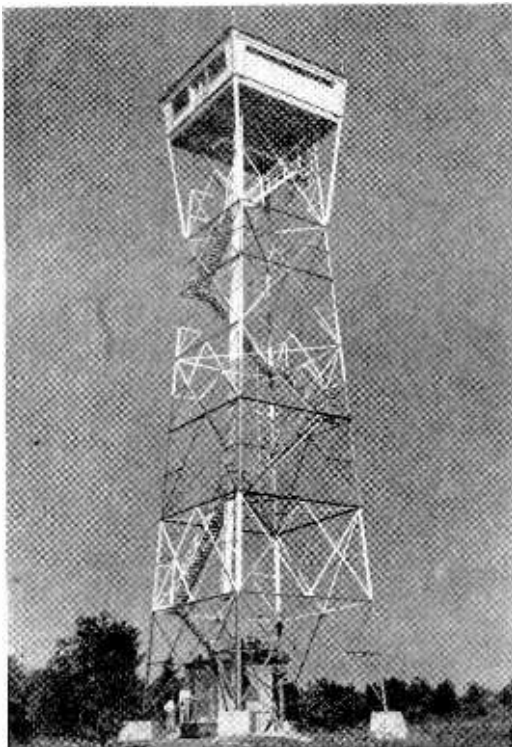

### New Television Relay Tower

This photo shows the new 130-foot steel tower just completed by General Electric in the Helderberg Mountains 12 miles from Schenectady, N. Y. The "house" atop the tower contains antennae, transmitting and receiving apparatus for the company's experimental micro-wave two-way radio network to operate between New York City and Schenectady as a carrier for television and FM radio programs, facsimile, and business machine circuits.

Under construction for the network are other relay towers on Beacon Mountain 50 miles from New York and at Round Top Mountain 52 miles farther north.



The Amplifier Corporation of America is interested in establishing a national service setup for servicing their post war amplifier (ACA-100DC). Men inquiring should be capable of handling service problems in these amplifiers, and strategically located. If interested, write Mr. N. M. Haynes, Amplifier Corp. of America, 396-398 Broadway, New York City, N. Y.

Page Twelve

## How To Get Along With Others

By DR. JAMES F. BENDER,  
Director, The National Institute for Human Relations

Copyrighted, all rights reserved

Did you know that it takes about thirteen facial muscles to smile? These muscles tug in all directions to give a variety of meanings. That is how we have the vacant smile, the smile of contempt, the cold smile, the smile of insincerity, the smile of love, and many others.

But the best smile of all—the one that makes the world whirl on greased bearings, that acts like a tonic to your human relations, that pays all sorts of wonderful returns—is the friendly smile.

Now the friendly smile is beyond all else sincere. We know it at first glance, and the mere mechanical smile, which is often a nervous mannerism anyway, never fools us. Neither are we taken in by the wooden smile that sometimes grimaces at us from advertisements. The most beautiful model in the world may be trained to use her smiling muscles in the "right" way, yet if the spirit isn't behind her smile, it never quite comes off.

The friendly smile springs from affection for these fascinating things called human beings and from a deep wish to help them. So it is that the secretary or the salesman or the lathe operator or the foreman (and all their brothers and sisters) who smile in genuine friendliness, smile with their whole being. This doesn't mean grimacing or "overdoing" it of course, but it does mean that their smiling muscles spring into action without reserve and with a certain gentleness revealing strength of character.

"Smile and the world smiles with you . . ." goes the old poem. How true it is when the smile is of the friendly sort and can be counted on in good times and bad!



# The 'NRI Professional Radio Tube Tester

## Now Available In Limited Quantity



tube tester is now available through NRI.

In designing this portable tube tester we gave particular attention to the following important features. Completeness of test. Ease of operation. Long life (freedom from obsolescence). Professional appearance. Cost.

The NRI tube tester is an emission tester, using the circuit type recommended by the Radio Manufacturers Association, Tube Division. Most tube testers use this basic testing circuit.

This is another NRI service to help our students and graduates. When you feel you are ready for a tube tester you may wish to consider the NRI Professional Radio Tube Tester, model 66. Space does not permit us to cover all of the interesting details here but, upon request, we shall gladly send you a circular giving complete information regarding specifications and price.

We have a limited supply of these radio tube testers in stock and others are on order. Deliveries from the manufacturer are somewhat slower than was anticipated, but we believe that we will soon have sufficient instruments to take care of all orders promptly.

This announcement is merely to inform you that NRI has done something about the question "Where can I get a good radio tube tester, suitable for my purposes and at the right price." If you are interested in receiving a circular regarding this tube tester simply fill in the coupon at the bottom of this page. Of if you prefer, send a post card requesting circular number 81.

**D**URING recent years we have received many letters from students and graduates asking for advice regarding the purchase of a radio tube tester. Knowing that many of our students are interested in purchasing a tube tester when they start earning from their radio servicing work, we decided that we would be doing our students and graduates a real service by designing a tube tester which would be ideal for their purposes. This announcement is to tell you that such a

  
**CLIP**  
**THIS**  
**COUPON**  
**FOR**  
**CIRCULAR**  
**DESCRIBING**  
**TUBE**  
**TESTER**

<b>NATIONAL RADIO INSTITUTE</b>		
Supply Division		81
16th & U Sts., N. Y.		
Washington 9, D. C.		
Without obligation to me, please send me a circular describing the NRI Professional Radio Tube Tester, Model 66.		
Name .....	Student Number .....	
Address .....		
City .....	Zone .....	State .....

# Recent Additions to the NRI Staff

Since NRI was established in 1914—now 32 years ago—our student body has increased every year. We are the largest institution in the world devoted entirely to training men and young men for good jobs in the Radio industry.

NRI today has a total of 197 employees, all of whom devote their entire time to teaching and serving our Students and Graduates.

Here are six recent additions to our staff whom we want you to meet. They were carefully selected for their specialized experience and qualifications.



**Edward M. McCormick**  
Graduate of Kansas State Teachers College, Bachelor of Science degree. Taught college mathematics. Radar instructor, Army Air Forces, during the war. Articles in "Radio," "QST," and "ARRL Handbook." Holds First Class Radio-telephone Operator's License. Member of I.R.E. and associate member of A.R.R.L.

**George Hartman**  
Student Service Department specialist on enrollments under "GI Bill of Rights." A veteran of four years' service with U. S. Coast Guard; discharged in 1945 with rank of Lieutenant (jg). B.S. degree in Business Education from State Teachers College, Indiana, Pa. Graduate work at Harvard University.



**William F. Dunn**  
Laboratory Instructor. Interested in Radio since 1936. Serviced receivers prior to enlistment in Navy. Attended Radio Materiel School at Naval Research Laboratory. In complete charge of installation and maintenance of Naval Shore Station overseas. Holds Radio-telephone First Class License.

**Frederick F. Edwards**  
A veteran of World War II, Edwards handles correspondence with veterans, who enroll for NRI training under the "GI Bill of Rights." Graduate of Coe College, Cedar Rapids, Iowa, 1936, Bachelor of Arts degree. Served in U. S. Navy as a Naval Aviator (Lieutenant) from 1941 to 1946.



**Harold L. Emerson**  
Served as a Naval Radio Instructor, and later as Chief Radio Technician aboard a destroyer during World War II. Educated at Heidelberg College and Tiffin University. Emerson is the new Assistant to Mr. L. L. Menne, who is Director, Graduate Service Department, and Editor of NATIONAL RADIO NEWS.

**Ernest B. Mullings**  
Laboratory Instructor. Attended AAF Radio Mechanics School at Madison, Wisc.; AAF Electronics School at Chanute Field; AAF Radar School at Boca Raton. Instructor in Radio receivers at AAF Radio Mechanics School at Truax Field. Came with NRI after discharge from service in 1946.



# NEWS OF THE RADIO WORLD

BY

*H. L. Emerson*

Between 20,000 and 30,000 television receivers, it is expected, will be produced and delivered to dealers in time for pre-Christmas purchase as shown by a recent survey. The manufacturing tempo will increase steadily from now on, hitting its stride sometime next year, according to the manufacturers' predictions.

**It has been found practical**, on the basis of tests made by Bendix Radio Corporation on the lines of the B & O Railroad, to use v.h.f. communication in tunnels. A special system which includes antennas at the tunnel's mouth and a single wire running through it produces loud signals.

**Vibrotion Tube.** RCA has announced a new product available to manufacturers. The new tube is essentially a triode with an electrode movable externally. One use for the new device is as a direct phonograph pickup. Other uses wherein a mechanical motion is desired as a current variation will suggest themselves.

**A radio engineer** recently testified that condemnation proceedings, which would move a roadway nearer his home, would cause considerable interference with radio and television signals thereby depreciating the value of his land. He was awarded \$3,400 more in court than the state of Connecticut originally proposed to pay him.

**Recently RCA announced** a television pickup relay apparatus capable of relaying signals from the pickup point to a television transmitter within a 15 mile range. The new equipment operates at any selected frequency in the 6500-7050 megacycle band. It produces a frequency modulated signal with approximately 100 milliwatts of power for the picture carrier and a band width that permits reproduction of the finest detail in the camera picture. A highly directional parabolic transmitting antenna enables the equipment to obtain a signal gain of about 5000 times with a 4 foot reflector or 11,500 times with a 6 foot reflector, giving the equivalent of a transmitter power of 500 or 1150 watts, depending on reflector size. To secure this high gain, a peculiar looking hook-shaped wave guide literally pours power into the focal point of a saucer-like reflector, much as the filament in an automobile headlight sends its light radiation (and light rays are similar to radio waves) to a concave reflector for intensification. The same principle is employed at the receiving unit, where the parabolic reflector receives the signal and concen-

trates the beam of radio energy into a wave guide to add another gain of 5000 or 11,500 times.

**A new tube** which performs *six* functions at once is being used in the Model 8H032 Zenith table AM-FM set. Also built in is an exclusive power-line antenna, which is said to pick up FM from electric light lines, eliminating the need for a separate dipole. The set is to retail for less than one hundred dollars.

**Invisible infrared light beams** "carried" the voices of German and Japanese soldiers across rivers and gorges and over distances up to ten miles during the latter part of the War. Both nations developed wireless telephonic equipment that utilized infrared light to transmit spoken communications. Words spoken into a microphone were transformed into electrical impulses which vibrated a mirror reflecting light beams through space. At the receiving end, a photo-sensitive receiver picked up the vibrating light beams (made invisible by filters) and changed them back to the original spoken words. The instruments resembled small searchlights mounted on tripods and varied in weight from 30 to 210 pounds. Several sets captured in 1944 and 1945 were sent to North Western University to be tested and analyzed by W. S. Hucksford and A. H. Nathercot, Jr., of the Department of Physics. The German instruments were examples of fine workmanship, containing optical units made by Carl Zeiss of Jena. The Jap units were more sturdily built and required simpler adjustments. Amplifying tubes in the Jap sets were copies of American tubes made ten years ago. Professor Hucksford said peacetime applications of this method of signalling are limited to short-range, line-of-sight communication to supplement radio or to supplant blinkers. With more improvements, the apparatus could be used in harbors and airports where radio-wave bands are already jammed.

**Visible Speech.** A new electronic device makes visible records of speech sounds. The spoken word is reproduced as a pattern upon a moving belt or upon the screen of a cathode-ray tube. Anyone trained in interpreting the pattern can repeat the sounds aloud. This is of special value in teaching language to deaf persons. A deaf pupil speaks at an unnatural pitch because he cannot hear his own voice. Training in the pattern method may permit development of normal inflection.

# How Circuit Diagrams Are Used In Servicing

By J. A. DOWIE

NRI Chief Instructor



J. A. Dowie

One of the important steps in becoming a professional serviceman is learning to use the servicing aids furnished by set manufacturers. Schematic wiring diagrams, pictorial layouts, tube layouts, alignment information—the professional uses them all, for he knows they help him to service receivers better.

Schematic wiring diagrams are particularly helpful. A receiver holds few secrets from the expert who has a diagram. Without even examining the set itself, he can often locate the probable cause of a defect and determine how to test for it just by glancing at the diagram.

**The Service Manual.** A collection of the most needed diagrams, in manual form, is very useful. Recognizing the need for such a manual, NRI has prepared one exclusively for students and graduates.

## Schematic Diagrams

The most important of the service helps is the schematic circuit diagram. This shows the *electrical* connections of a receiver in their simplest form. However, it does *not* show the exact *physical* connections.

There is a very important reason for not showing the actual wiring in a schematic diagram: the circuit is much clearer in the schematic form. For example, Fig. 1A shows a B+ supply circuit as it might be shown on a schematic. See how easy it is to trace from the filament of the rectifier through  $L_4$  (the speaker field coil) to the i.f. transformers  $L_1-C_1$  and  $L_2-C_2$ , to resistor  $R_1$  and to the output tube screen grid and plate circuit (through  $L_3$ ). But now try to trace the same B supply circuit in Fig. 1B, which shows the *actual* wiring! Although the

electrical connections are exactly the same in both circuits, the schematic is far easier to read. This is because the schematic is drawn to show the *purposes* of the circuit connections, whereas the wiring layout is simply a picture of the way wires are led around to make the desired connections in a particular chassis.

Each type of diagram has its uses. The schematic is very useful when you are trying to find out just how a set works. On the other hand, the wiring layout is far handier when you are trying to identify parts and wires (although, as we will show later, it is perfectly possible to identify parts from a schematic, too.) Let's pass over other kinds of diagrams for the moment and investigate the uses of schematics.

One important way in which a schematic helps a trained serviceman is by pointing out possible causes of a defect. For example, suppose an experienced Radio-trician is servicing a receiver that oscillates (squeals). He at once suspects that a by-pass condenser is open, or that one or more tubes have excess screen voltages. Does he then proceed to check all the by-pass condensers and all the screen voltages? No—first he glances at the diagram, and from it decides which part (or parts) most likely are defective.

An open in the screen by-pass condenser marked C1 in Fig. 2, for instance, might well be the cause of regeneration and squealing. The cathode by-pass condensers marked C<sub>2</sub> and C<sub>3</sub>, however, could not cause regeneration even if they were open; rather, degeneration (the opposite of the regeneration that causes squealing) would occur if these condensers were open. This is always true of a cathode by-pass condenser *used for a single tube*.



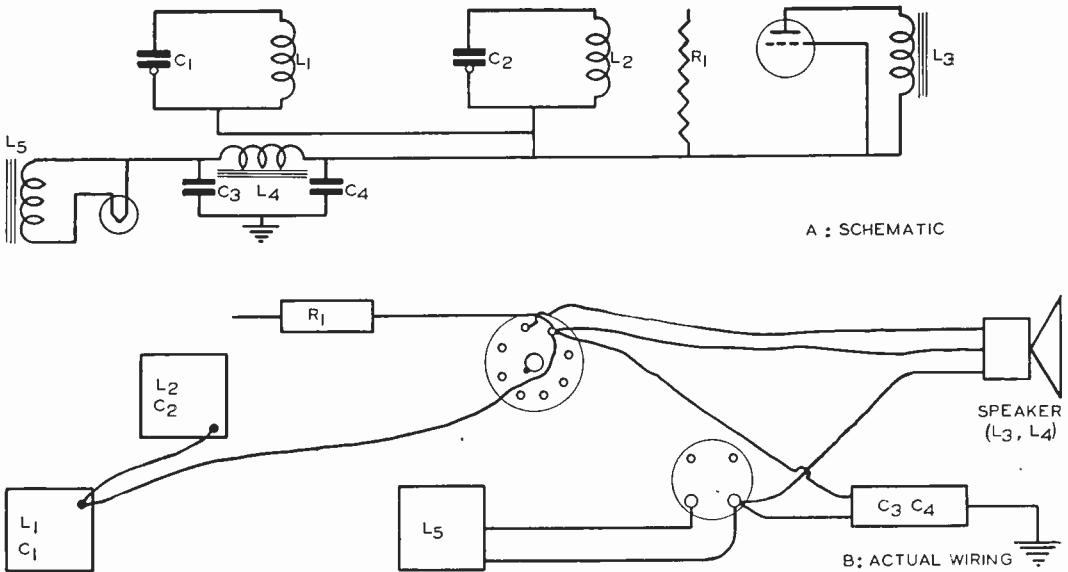

Fig. 1

However, all cathode by-pass condensers are not incapable of causing oscillations. If two tubes operating at the same frequency use a common cathode by-pass condenser and bias resistor, as shown in Fig. 3, an open in the condenser  $C_2$  will allow feedback from  $VT_2$  to  $VT_1$  to occur, and, if the phase relationship is proper, oscillation may result. You can see how valuable a schematic is, in this case. With the aid of a schematic, you can determine at once whether you have a circuit like that in Fig. 2, in which condenser  $C_2$  cannot be at fault, or a circuit like that in Fig. 3, in which a similar condenser  $C_2$  may well be the cause of the trouble. Either way, your testing is made simpler because you know what to test. Without a diagram, it would be more difficult for you to determine which type of circuit you have, so you would probably test all the by-pass condensers in the defective stage or section.

To carry our example further, suppose that a by-pass condenser is not at fault, and suppose that the screen voltage of a stage is excessive. Again a Radio-trician would look at the diagram to see where the defect might be. If the circuit were like that in Fig. 4A, resistor  $R_1$  would have to decrease in value before the screen voltage could increase. You would therefore check the value of this resistor with an ohmmeter. However, if the circuit were like that in Fig. 4B, excess screen voltage most likely would be caused by an open in bleeder resistor  $R_2$ . In this case, then, you would check from the screen to ground with an ohmmeter to see if you measure the correct resistance value. (Incidentally, ohmmeter tests are always made with the set turned off—otherwise, the meter might be ruined by being connected across a high voltage.)

As you see, the serviceman must know the circuit

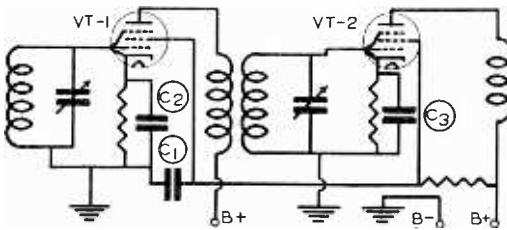

Fig. 2

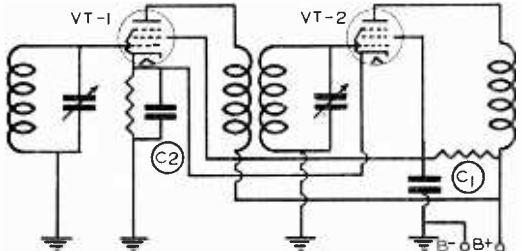

Fig. 3

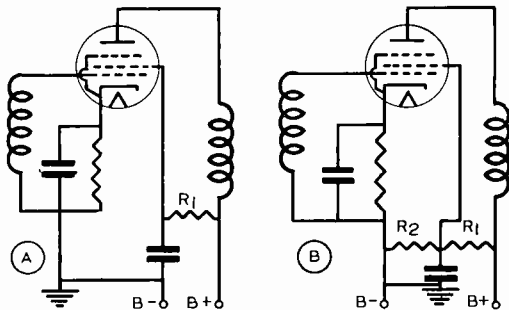

Fig. 4

before he can tell which test to make. He has two choices—he can find out what the circuit is by glancing at a diagram, or he can spend several minutes attempting to trace the circuit through the set wiring. Naturally, he prefers to use the circuit diagram.

Although we have chosen an oscillating set as an example in showing you how the schematic diagram is used to speed up servicing, do not assume that oscillation is the only complaint in which a schematic is helpful. We might equally well have chosen some other complaint, for a schematic can be used profitably in a great variety of servicing jobs. For instance, you know that hum may be caused by cathode-to-heater leakage in an audio tube. But hum can result *only* if there is an impedance between the cathode and ground, across which the hum voltage can develop. If the complaint is hum, then, you can use a schematic to see if such impedance exists. In a cathode circuit like that in Fig. 5A, leakage will cause a hum voltage to exist across  $C_1$ - $R_1$ , because the leakage will allow part of the filament voltage to be applied to this combination. On the other hand, if the cathode is directly grounded as in Fig. 5B, leakage cannot cause hum; there is no impedance to the cathode circuit across which a hum voltage can develop. Thus, a glance at the schematic will show you whether you need to consider cathode-to-heater leakage when you are servicing a set for hum.

**Appraising Receiver Performance.** Schematic diagrams can also be used for purposes other than locating probable defects. For instance, a quick survey of a circuit diagram will give you sufficient information to appraise the performance of a radio receiver. This appraisal will tell you whether you can expect good distant reception, or whether the set is intended only for local and semi-distant reception. It will also tell you what to expect in the way of sensitivity and selectivity, once you know the factors that determine these performance characteristics. Customers sometimes demand receiver performance far beyond that which the set can give. To prevent your wasting time trying to improve a set, you should

know when a receiver is performing as well as can be expected. This ability to appraise receiver performance from a circuit diagram will come to you almost automatically as you progress further in your radio studies.

**Use of Diagrams in Aligning Receivers.** A circuit diagram reveals the various circuits that must be adjusted during a receiver alignment (tune-up) procedure. With this information, the Radiotrician can generally locate the various adjustments on the chassis and carry out the alignment (though sometimes he needs special alignment information furnished in other service aids).

Of course, the Radiotrician almost never reads a *complete* receiver circuit diagram while servicing any receiver. The professional servicing

IF CATHODE-TO-HEATER LEAKAGE OCCURS -

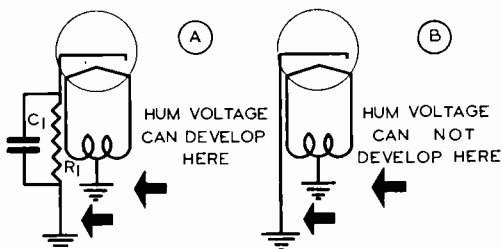

Fig. 5

technique enables him to isolate the defect almost at once to one section of the receiver, and that section is the only one he studies in detail.

Now that you've learned the major use of schematic diagrams, let's see what other service information is available, and how it is used.

#### Layout Diagrams

There are several types of layout diagrams that are usually a part of the service manual. One of these is the tube layout diagram.

This tube layout diagram tells what tubes are used, shows exactly where they will be found on the chassis, and indicates the stage in which each is employed. A tube layout diagram generally indicates tube positions as seen from the top of the chassis, but with a little experience you can make this diagram serve just as well when you work on the bottom of the chassis. A tube is also readily identified by its relation to adjacent, easily-recognized parts.

**Tube Charts.** When you turn over the chassis of a receiver to get at the socket terminals for a particular tube, you are confronted with the problem of identifying the various socket terminals. Some schematic circuit diagrams provide

this information by using a combination pictorial and schematic diagram for each tube, in place of the usual schematic symbols. Some manufacturers give tube socket connections on the tube layout diagram; others give the connections on the pictorial layout diagram (which we will take up in a moment). You can identify tube socket terminals even without these diagrams, however, because *tube manufacturers* prepare charts for servicemen that show the socket connections for all tubes. An example is shown in Fig. 6. When you are ready to begin actual work on radio receivers, secure one of these tube charts from your local radio parts distributor. As you acquire experience, you will become familiar with socket connections for the more common tubes and will be able to work on them without referring to any chart or diagram.

**Pictorial Layouts.** In many service manuals you will find, in addition to the diagrams just described, a pictorial layout diagram that shows the approximate position of each part on the chassis, and may also show the actual wiring.

The pictorial diagram is useful in that it shows the physical *position of parts*. In the type shown in Fig. 7, only the parts are identified and positioned, but others show the wiring also.

It is not always *necessary* to have all these forms of servicing data; in fact, most of the time a schematic is all you really need, and an experienced man can get along even without this type of diagram. You, too, will learn how to get along on a minimum of service information whenever such information is not available. Of course, it

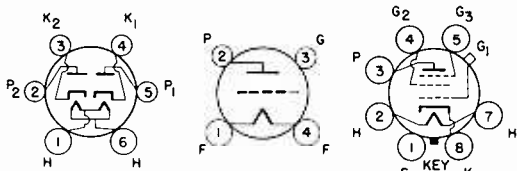

Fig. 6

is very convenient to have all this information, because, to check a receiver, you will have to identify stages so that you can introduce circuit disturbances and trace signals; you will have to locate reference points from which to test; and you will have to locate the suspected parts you wish to test. All these steps are speeded if you have the complete service data.

For example, to locate a part, you can use the circuit diagram to find the number by which the part is identified; then you can refer to the parts layout diagram to determine the location of the part having that number. It is then a simple matter to locate the part on the actual chassis. If identifying numbers are not given you can note the tube socket terminal to which

the part is connected on the circuit diagram, then can locate the same terminal on the pictorial diagram, and can trace the wiring from that terminal to the desired part.

The service information has other uses too. When you have located the defective part, the schematic diagram or an accompanying parts list will usually give you its correct electrical value. Knowing the value will frequently save you the trouble of ordering an exact duplicate resistor or condenser from the receiver manufacturer, because once you know what value the part should have, you can generally get an acceptable substitute from your local radio distributor. You must be careful, though, to get a resistor with the same or a higher wattage rating, and a condenser with the same or higher voltage rating. These ratings are not always given on parts lists, but you can estimate them readily, once you have mastered circuit theory.

### How to Identify Receiver Types

Perhaps the best way to show the value of service information is to show what you must do when it is not available. Let's take up the ever-present problem of identifying stages and parts. To show all the steps, we will suppose that you do not have a diagram.

Many of these tests to be made on a receiver depend on its power supply and its type (t.r.f. or superheterodyne). Therefore, let's first see how to identify the power supply.

The first step toward this identification is to look for a power cord equipped with a two-prong plug; whenever you see it, you know the receiver operates from a power line. Today, except in rare instances, this means the receiver is either a.c. or a.c.-d.c. type. (Once there were a few d.c. receivers in use in large cities, but almost all of these have been replaced by a.c.-d.c. sets.)

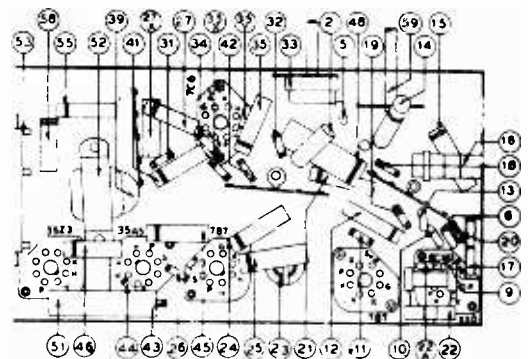

Fig. 7

The following rules will further help to identify the kind of power supply:

TABLE I			
GROUP I RECTIFIERS USED IN AC SETS		GROUP II RECTIFIERS USED IN AC-DC SETS	
5T4	5U4-G	12Z3	25Z5
5V4-G	5W4-G	25Z6	35Z3
5X4-G	5Y3-GT	35Z4 -GT	35Z5 -GT
5Y4-G	5Z3	45Z3	45Z5 -GT
5Z4	6X5	50Z7-G	117Z5 -GT
	80		

A. The set is an a.c. type if—

1. It has a power cord, and
2. it has a power transformer, and
3. it uses one of the rectifier tubes in Group I of Table I.

B. The set is an a.c.-d.c. type if—

1. It has a power cord, and
2. it has NO power transformer, and
3. it uses one of the rectifier tubes in Group II of Table I (Exception: the set may meet all these requirements and still be a straight a.c. type if it uses one of the Group II full-wave rectifiers in a voltage-doubling circuit.

C. The set is an older d.c. type if—

1. It has a power cord, and
2. it has NO power transformer, and
3. it has NO rectifier tube. (Note that a 37 or 76, grid and plate tied together, may function as a half-wave rectifier in some older midsets which appear not to have a "rectifier." Tracing the wiring will permit identification of rectifiers.)

Receivers designed for battery operation are usually equipped with a multi-lead cable having a battery clip or terminal lug at the end of each cable wire. There will usually be tabs or a color code to indicate the proper connection for each wire. Some battery receivers are designed to operate from a single 6-volt battery; these have only two leads in the battery cable. Others require B and C batteries in addition to an A battery, and will have many more leads in the cable. A battery receiver does not use a rectifier tube (except some auto-radio receivers and three-way portable receivers that operate either from batteries or from an a.c. or d.c. 115 volt line.

Identification of the type of power required by a receiver is essential when the most positive terminal and the most negative terminal in the power supply are to be located and used for electrode continuity-checking purposes.

**Type of Radio.** Super or T.R.F. There are a number of clues that identify a receiver as a

super; if these clues are absent, you know that you have a t.r.f. receiver. If the tuning dial indicates that you have an all-wave or a 2-band receiver, it is safe to say that it is a super. In the case of a single-band receiver, the presence of one or more i.f. transformers shows that it is a superheterodyne.

Most i.f. transformers are housed in small aluminum cans having one or (more often) two adjusting screws on the top, the bottom, or one side. Occasionally, however, the trimmer condensers and their adjusting screws will be located on the chassis near the transformer shields; in this case, identification of the transformer is somewhat more difficult. If there is a flexible lead going from a metal can to the top cap of a tube, but no lead going from the can to the tuning condenser gang, you can be sure the can houses an i.f. transformer.

You can also be sure that a single-band receiver is a super if it has six or more tubes but only two sections in its variable condenser, or if the rotor plates in one variable condenser section are shaped differently from those in the other, or if it uses a pentagrid converter tube.

Single-band receivers that do not have pentagrid converters or i.f. transformers are r.f. sets. *Four-tube* universal a.c.-d.c. receivers generally use a t.r.f. circuit, but you should always make sure by looking for the i.f. transformer, since there are some supers in existence that have only four tubes (including the rectifier tube). Receivers having four or even five sections in the gang-tuning condenser are generally older t.r.f. sets.

#### How to Identify Stages

With a little actual experience in servicing old and new radio receivers, you will find yourself able to identify the type of circuit and the power requirements of a radio receiver almost at a glance. Identification of the individual stages in a receiver is not quite so easy, but a knowledge of what to expect in t.r.f. and superheterodyne receivers, which you get from the NRI Course, will help considerably.

Tests for isolating the defective stage in a receiver may be carried out more or less readily without a schematic circuit diagram, once you locate and identify the various stages correctly. The tube used in each stage will be your most valuable clue. Its type number, its size and shape, and the appearance of its electrode structure (if it is a glass tube) should all be noted; and tube charts (supplied by various tube manufacturers) should be referred to in order to find the most common functions of a particular tube.

The identification of stages *without a circuit diagram*, is to a certain extent a process of elim-

ination. You must eliminate first the easiest stages to identify, so that you can concentrate on the remaining stages. It is common practice to identify the power supply first; this is done by locating the rectifier tube (if the set has one). The rectifier is usually the largest tube in an a.c. receiver, but this is not true in other sets. However, typical rectifier tube type numbers are given in Table 1, so you can identify the tube if the type number on it is readable.

Incidentally, examine a tube carefully for this number. It may be on the top or on the side of the glass or metal envelope, or it may be on the side of the base. Other numbers may also be on the base of the tube; these are usually factory identification codes and are NOT the type number if they do not correspond to any standard listing. (Sometimes the socket on the chassis will be marked to identify the tube to be used in it.)

Next you locate the power output stage. This will have either one tube or two identical power output tubes, and these will quite often be just as large or larger than the rectifier tube. You will learn eventually to recognize these tubes by their numbers. (Whenever you find *three* tubes that tube charts classify as power output tubes, one is acting as a driver for the other two.)

Now locate the receiver input stage. This is very often through an antenna (r.f.) transformer to one section of the variable tuning condenser. If there are only two sections in the gang tuning condenser, you know from circuit study that there is no r.f. amplifier stage, so you should look for the mixer-first detector. If you find a pentagrid converter tube, you have identified the oscillator-mixer-first detector stage.

If the gang tuning condenser has three sections, either the receiver has an r.f. stage, or there is a band-pass input circuit to the mixer-first detector tube. Usually, you can identify the r.f. tube as a variable-mu pentode (or screen grid) tube, and its control grid circuit will be connected to one section of the gang tuning condenser. When the tube has a top cap, you will see a wire going to the stator of one of the condenser sections.

You can now tentatively identify any other variable-mu pentode (or screen grid) tubes as i.f. amplifier tubes. For more positive identification, locate the i.f. transformers (remember that an i.f. transformer is in a small aluminum can having adjusting screws on the top, bottom or side). You must be able to distinguish between the i.f. transformers and the shielded r.f. coils (used in preselector-mixer-first detector and oscillator circuits); when in doubt, you can identify the latter coils by the fact that they are connected under the chassis to the tuning condenser or to the wave-band switch.

You can also identify i.f. stages by tracing circuits under the chassis. Start at the mixer-first detector tube, which you have already identified, and trace from its plate terminal to the first i.f. transformer. From the secondary of this transformer you will be able to trace to the grid of a tube either through a flexible top-cap connection coming from the transformer, or through a lead to the grid terminal of a tube socket. That tube will then be the first i.f. amplifier tube. If there are two i.f. stages, you will be able to trace from the plate of the first amplifier tube to the primary of another transformer, and from the secondary of that transformer to the grid of the second i.f. amplifier tube.

You can identify the second detector at once when you have located the i.f. stage or stages. In most cases, it will contain a diode tube (or a triode connected as a diode), which will be coupled through a transformer to the plate of the last i.f. tube.

A triode tube that is located near the second detector tube or near the output tube can be identified tentatively as an audio, or driver, tube; it may or may not have a top cap. If you can trace from the plate or load of the second detector to the grid of this triode, you have an additional identification; and if you can trace from the plate of this triode tube through a resistor, an iron-core choke coil, or a transformer winding to the high voltage terminal of the power pack, you can positively identify the tube as the first audio amplifier tube.

The set may not contain a separate audio, or driver, tube. If not, the second detector will be the diode part of a dual-diode-triode and will use the triode as the audio amplifier. In a few of the older receivers, the second detector is a triode or pentode tube and may feed directly into the power output stage.

If there are still some unidentified tubes left on the chassis after you have completed the identification of stages up to this point, they are probably phase inverters or special control tubes. These are not easily identified even by an expert until their circuits are traced. If you must know their functions, the best procedure is to secure a circuit diagram for the receiver. Cathode-ray tuning-indicator tubes (magic eyes) can, of course be identified by their appearance.

A t.r.f. receiver will have one or more tuned r.f. amplifier stages, a demodulator (detector), and a power audio output stage. In some sets an audio voltage amplifier, before the output stage, is used. The r.f. stages are easily located, for the grid of each r.f. tube will be connected to one of the stators of the gang tuning condenser, *not* the rotors; the rotors are invariably grounded. If there are three sections in this condenser, there will be two r.f. amplifier tubes, and the third

section will connect to the detector tube. If there are four sections, there will be three r.f. amplifier tubes, unless two sections are used in a band-pass circuit.

When you have identified the stages in a receiver in this manner, you can make tests for isolating the defective stage, even though a schematic circuit diagram is not available. You can then proceed to make continuity tests between tube electrodes and the most positive and most negative d.c. supply terminals, since you know the type numbers of the tubes in the receiver and can determine their socket connections by referring to a tube chart.

#### How to Identify Parts

When you locate a tube electrode circuit that lacks continuity, you then proceed to locate the part or connection that is open. If a circuit diagram is available, you can trace out this particular electrode circuit on the diagram and can note the parts in it, then you can locate those parts on the actual chassis (possibly with the aid of a pictorial layout diagram). For example, if an ohmmeter test reveals lack of continuity in the plate circuit of an i.f. amplifier stage, the schematic circuit diagram (see Fig. 8) may indicate that the circuit traces from the plate terminal of the tube through the primary ( $L_1$ ) of an i.f. transformer, through resistor  $R_1$  that is used in conjunction with by-pass condenser  $C_2$  as a filter, and then back through choke coil  $L_2$  in the power-pack filter system to the cathode of the rectifier tube. If you suspect resistor  $R_1$  of being open, then locate it on the pictorial diagram

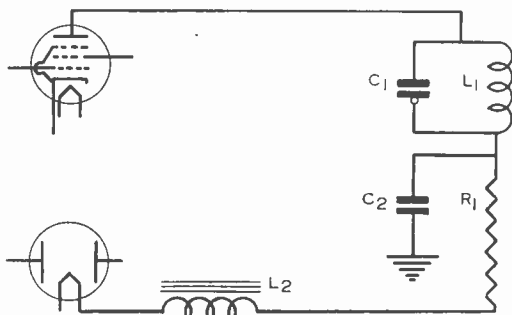

Fig. 8

so that you can find it easily on the chassis. Once it is located, check it with an ohmmeter.

The procedure for locating an open in an electrode circuit when a circuit diagram is not available is much the same, though not as easy; you will have to learn more circuit theory before you can locate defects readily without a diagram. When you have acquired the necessary knowl-

edge, here's how you'll find the defective part:

Since resistors and coils are the only parts that can provide continuity in an electrode supply circuit, these are the only parts you look for on the chassis. For example, let's say you have isolated a defect in the plate circuit of the i.f. amplifier stage as in the last example. To find the faulty part, you will connect one probe of your ohmmeter to the rectifier cathode and will start tracing through the defective circuit by touching the other probe to various points in the circuit.

You will start at the plate terminal of the tube and will look for the i.f. transformer primary (which is invariably connected directly to an i.f. tube plate). You will trace through this primary winding to determine its other terminal, either by inspection or by making a continuity test with an ohmmeter; then you will look for a filter resistor whose other terminal is connected to the high-voltage positive terminal of the power pack. You will next look for a connection between this high-voltage terminal and the filter choke, either direct or through one or more resistors. The filter choke, of course, connects to the cathode of the rectifier tube, at which you have one ohmmeter probe.

As you locate each part in the i.f. plate circuit, you will touch your free ohmmeter probe to each of the part's terminals (touching it first to the terminal nearer the plate of the i.f. tube). Eventually you will find the defective one; you will recognize it at once, because you will get no ohmmeter reading (that is, your ohmmeter will show infinite resistance) when you touch the probe to the part terminal nearer the plate of the i.f. tube, but you will get a reading when you touch the probe to the other terminal (the one nearer the rectifier cathode). Thus, it is possible to check a circuit without having a diagram, once you know what parts are normally found in various electrode circuits. Naturally, however, the process of locating and identifying parts takes longer without a circuit diagram, since there are often a great many possible variations of electrode circuits, each of which you must check. Whenever possible, to speed the work, obtain and use the diagram of the radio.





# N.R.I. ALUMNI NEWS

Harry R. Stephens .....	President
Ernest W. Gosnell .....	Vice-Pres
Frank Zimmer .....	Vice-Pres
Harry Andresen .....	Vice-Pres
F. Earl Oliver .....	Vice-Pres
Earl Merryman .....	Secretary
Louis L. Menne .....	Executive Secretary

## ZIMMER OF NEW YORK AND OLIVER OF DETROIT ARE NOMINATED FOR PRESIDENT

### A Strong Slate For Vice Presidents Is Also Placed In Nomination

In a spirited campaign which saw one hundred and sixty-eight different candidates receive votes for nomination for one office or another, the final tally shows Frank Zimmer of New York and F. Earl Oliver of Detroit on top. These two men have been nominated for the Presidency of the NRI Alumni Association.

Twenty-two men in all received votes for nomination for President. When the final count was in, Zimmer and Oliver were the two with the greatest total of votes and they, therefore, are hereby declared nominated.

In the contest for Vice-Presidents, we also had a good race. Fifty-six men received nominating votes for Vice-Presidents. Zimmer and Oliver were also high on this list but, being nominated for President, they are eliminated as candidates for Vice-Presidents. Ernest W. Gosnell of Baltimore, Harry Andresen of Chicago, Harry R. Stephens, our retiring President of Detroit, William Peterson of Jamaica, New York, James J. Newbeck of New York City, Charles J. Fehn of Philadelphia, Dr. George B. Thompson of Los Angeles, and Jacob J. Knack of Cleveland make up the list of candidates.

For Secretary, our good friend Earl A. Merryman was easily nominated. The next highest number of votes for Secretary was received by Louis J. Kunert, of New York Chapter.

For the office of Executive Secretary the nominees are L. L. Menne of Washington, D. C., and J. J. Jenkins also of Washington, D. C.

Such ever reliable stand-bys as Gosnell, Andresen, Stephens and Fehn will run strong. It is interesting, too, to find Dr. George B. Thompson back as a candidate for Vice-President. It is also pleasing to present some new candidates in the persons of William Peterson and James J. Newbeck, both of New York Chapter and Jacob J. Knack of Cleveland, Ohio, who has no chapter affiliations. It is a real feather in the cap of Mr. Knack to be nominated in this strong field.

Harry R. Stephens still has until December 31 to serve as President. He has done an excellent job and our members are deeply grateful for his conscientious efforts to keep our Alumni Association moving forward. Mr. Stephens has earned the warm affection of our members.

Now, if you are a member of the NRI Alumni Association, will you please turn to page 27 of this issue where you will find a convenient ballot for you to mark. Kindly fill in the ballot and mail it promptly. All elected officers shall serve a term of one year. We urge every member of the NRI Alumni Association to participate in this election. Your cooperation will be greatly appreciated.

Mark your ballot and mail it now. Mail it to C. Alexander, Bookkeeper, c/o National Radio Institute, 16th and U Streets, N.W., Washington 9, D. C. Mr. Alexander will head a committee of Tellers to count the votes. Successful nominees will be announced in the next issue of National Radio News.



## New York Chapter

The annual social party for New York Chapter will be held November 21, which is just too late to be reported in this issue. However, we will have complete details for the next issue of the NEWS. This is always a big affair.

Here are some of the highlights regarding some of the recent meetings. James Newbeck continued his discussions on Oscillation. William Fox related some of his Radio experiences in his characteristic style. Mr. Fox has a keen sense of humor and when he relates the humorous experiences he has had, it is comparable to a vaudeville show.

Our attendance continues to be better than sixty at each meeting. At one meeting we had 76. Of these, 74 were regular members and two were guests. We have a fine, loyal bunch of members who need little urging to come to our interesting meetings. Pete Peterson, by the way, missed one meeting, the first since he joined the chapter. We excused him because he has so much work in his repair shop he simply could not get away on this particular night.

New members are, J. D. Arena, D. Murphy, W. Decker, E. Reide, E. J. Surgosh, N. DiToro, S. Fried, P. Engler, E. J. Herzberg, J. Murray, P. Dougherty, Bernard A. Geisler, Thomas Crowe, and Delevan Beatty. Welcome to New York Chapter. Remember, fellow members, that regular attendance at Chapter meetings is very important. We need you and you need us.

At another meeting, Pete Peterson, who as previously mentioned, is a red hot service man conducting his own service shop, took his stand in the Questions and Answers Box and gave us a lot of real practical help. At the same meeting Edward Karpfe, a Radio Engineer, gave us an interesting talk on some new ideas in the industry, and George Hirsch gave us a talk on Mathematics in Radio.

Lloyd Jonassen started a series of talks on "Using the Communications Receiver as a Servicing Instrument." Jonassen is a young man of much promise. He is a very capable speaker and knows radio. His talk was followed by Alex Remer, who spoke on "What Makes a Radio Click."

Alex Remer, from time to time, conducts his  
Page Twenty-six

Radio Quiz. I. Weinberg spoke to us on practical Radio problems and solutions. We have a lot of good Radio service men in our Chapter and we always have plenty of good speakers.

To fill a vacancy caused by a resignation, Chairman Wappler appointed Richard Patten to serve as our Librarian. He is a graduate and has been with us for about a year. He makes the trip from Staten Island for each meeting and is very regular in his attendance.

Meetings are held on the first and third Thursday of each month at St. Mark's Community Center, 12 St. Mark's Place—between 2nd and 3rd Aves., New York City. Meetings begin at 8:15 P. M.

Louis J. Knuert, Secretary  
145-20 Ferndale Ave.  
Jamaica 4, N. Y.



## Phila-Camden Chapter

John Biacelli gave us a talk on FM, using the block diagram method to show the different stages the signal passes through and how the circuit works as a complete Radio.

At another meeting we had a representative of the Bell Telephone Co. give an illustrative lecture on mobile Radiotelephone service entitled, "You Can Take it With You." All arrangements for this meeting were made by Charles Fehn.

Harvey Morris took charge of one meeting using our RCA Dynamic Demonstrator, and as luck would have it, dampness had set in. This gave Harvey a fine opportunity to show us the damage that can be done through dampness or other carelessness.

We are very pleased to announce the acceptance of a number of new members, as follows: Leon Williams, Jr., and Paul Deterling of Downingtown, Pa.; Paul Voelmle, 4537 N. 18th St.; Morris Segal, 3949 Wyalusing Ave.; Llewellyn Henry, 3335 N. Bouvier St.; Ray Hamilton, 2234 S. Lambert St.; Alfred M. Evans, 2832 N. Front St.; John W. Seibel, 3419 N. Ormes St., Phila., Pa.

Our committee to purchase tools for the Chapter showed up with some fine equipment, side cutters, diagonal cutters, sheep nose pliers, and assorted number of screw drivers, an electric iron and stand and two extension cords and plugs. Little by little we are getting all of the things we need to conduct a service program.

On December 7 we expect our Executive Secretary to come from Washington and perhaps some others from headquarters to be with us.



Meetings are held on the first and third Thursday of each month in the Post Office Building, 4706 Comly St., Philadelphia.

F. Armstrong, Secretary  
7416 Georgian Rd.  
Philadelphia 38, Pa.

— n r i —

### Detroit Chapter

Things are certainly on the move in Detroit Chapter. Our own member, Floyd Buehler, who is a Radio instructor at a school here in our city, was our speaker on October 18. Mr. Buehler gave us an interesting evening. In addition to his very fine talk he showed sound pictures and demonstrated a lot of laboratory equipment. It was a bang-up meeting.

At another meeting we showed the movie "The Magic of Fluorescence," through the courtesy of General Electric Co. This picture was very well received by all. Then followed a very interesting discussion, led by Duncan Jacques on the NRI Lesson, "How Sound and Scenes are Converted into and Reproduced from Electrical Signals." At the close of the meeting refreshments were served.

W. L. Wayman was our principal speaker at one of our meetings. He gave us a most interesting talk, especially on the purchasing of high type Radio condensers, on the one hand, and buying bargain assortments of unknown make, on the other. He elaborated too, on some of the fields, other than Radio servicing in which the Radio man can operate, such as wiring cemeteries for sound, athletic fields, movie houses, cabarets, etc.

Henry Rissi, well known Detroit service man, and honorary member of Detroit Chapter, conducted his popular open forum. Members are encouraged to ask questions and Mr. Rissi supplies the answers in down on the ground Radio serviceman's language.

Harold Chase and Alex Nikora have been appointed a committee to look into the proposition of obtaining new meeting quarters. They are to make a report at our next meeting.

Dale Rich of Garden City, Harry E. Hubbard of Lincoln Park, Mich., and Leonard Winkelmann of East Detroit, are our newest members. All swell fellows and they are very welcome in our ranks.

The big news was held for the close of this report. Chairman Jim Quinn appointed a committee of two, Vice President Earl Oliver and Larry Upham, to purchase an appropriate gift to be presented to Harry R. Stephens to commemorate

(Page 30, please)

### Election Ballot

Fill in this ballot carefully, following instructions given on page 25. Mail your ballot to National Headquarters immediately.

#### FOR PRESIDENT (Vote for one man)

- Frank Zimmer, New York, N. Y.
- F. Earl Oliver, Detroit, Mich.

#### FOR VICE PRESIDENT (Vote for four men)

- Ernest W. Gosnell, Baltimore, Md.
- Charles J. Fehn, Philadelphia, Pa.
- Jacob J. Knack, Cleveland, Ohio
- Harry R. Stephens, Detroit, Mich.
- Harry Andresen, Chicago, Ill.
- Wm. Peterson, Jamaica, N. Y.
- James Newbeck, New York, N. Y.
- Dr. George B. Thompson, Los Angeles, Calif.

#### FOR SECRETARY (Vote for one man)

- Earl A. Merryman, Washington, D. C.
- Louis J. Kunert, New York, N. Y.

#### FOR EXECUTIVE SECRETARY (Vote for one man)

- L. L. Menne, Washington, D. C.
- J. J. Jenkins, Washington, D. C.

#### SIGN HERE:

Your Name .....

Your Address .....

City ..... State .....

Polls close December 30, 1946. Mail Your Completed Ballot to:

C. ALEXANDER, BOOKKEEPER  
NATIONAL RADIO INSTITUTE  
16th and U Streets, N. W.  
WASHINGTON 9, D. C.

## Don't Quit

When things go wrong—as they oftentimes will;  
When the fight you're making is all "up hill";  
When funds are low and debts are high  
And you try to smile but are forced to sigh;  
When cares sap your energy, every whit—  
Rest, if you must, but don't you quit!

Life is strange, with its twists and turns—  
As, sooner or later, each of us learns—  
And many a beaten man turns about  
When he might have won, had he stuck it out!  
Never give up! Nor pause to fret!  
You may arrive with one more step!

Success is failure inside out—  
The "silver tint" of the "cloud" of doubt—  
And you never can tell how close you are;  
It's often near when it still seems far.  
So, still fight on when you're hardest hit!  
It's then, most of all, you shouldn't quit!

—Anonymous.



For the LAST TIME, Mr. Woggle—NOW  
you buy your Radio parts OVER the  
counter!

## Baltimore Chapter

We were pleased to have Mr. Harry R. Stephens, our Alumni President, visit us quite by surprise. He was accompanied by L. L. Menne and H. L. Emerson, from headquarters. Mr. Stephens spoke to us briefly and stayed after the meeting to chat with our members. He is a very fine fellow.

Many good lectures have been given at our regular meetings during the past year and the interest created by these lectures is reflected in our much improved attendance. This is very gratifying to the officers of our Chapter. Interest is at a high peak.

Page Twenty-eight

Some of the lectures given by Chairman Rathbun were on subjects as follows:

Power Supply of AC Radio Receivers  
Power Supply of Automobile Radio Receivers  
Basic Principle of Magic Eye Tuning Indicator  
Basic Principle of Colorama Tuning Indicator  
Fundamental AVC Circuits  
Alignment of AC-DC Midget Receivers  
Alignment of Superhet. Radio Receivers, Single and Multi Band.  
Locating Faults in Radio Receivers, Etc.

In addition to these interesting lectures, several demonstrations were made by various members. Some of these demonstrations were as follows:

Alignment of Radio receivers with signal generator and vacuum tube voltmeter—by Mr. Clark.

How to find impedance value of inductors by means of an oscilloscope, ohmmeter, rheostat, and source of modulated signal—by Mr. Ingram.

How to use signal tracing equipment to find gain per stage or locating faults in Radio receivers in case the gain per stage is below par—by Mr. Clark.

Testing power supply with oscilloscope and the typical patterns obtained under normal and abnormal conditions—by Mr. Rathbun.

Oscilloscope with sweep circuit and Frequency modulated at 1000 KC—theoretical and practical consideration. Response curves, alignment, gain per stage, etc.—by Mr. Arthur.

All of our members are invited to make suggestions as to the type of lecture or demonstration they would like to hear and see. We realize that all members cannot assimilate all the good points in lectures and demonstrations—because some of our students are not sufficiently advanced in their studies—while others who have been students or graduates for some time probably know as much as the person giving the lecture or making the demonstration. It is felt that if many or even a few derive some additional knowledge, or benefit from our lectures and demonstrations the efforts of those giving these talks are well rewarded. In all cases, after the lectures and demonstrations, the members present are requested to ask questions on all matters which seem to them to need a little clearing up.

Meetings are held on the second and fourth Tuesday of each month, at Redmen's Hall, 745 West Baltimore St., Baltimore, Md., at 8:15 P. M.

P. E. Marsh, Secretary  
Box 2556, Arlington Sta.  
Baltimore 15, Md.



## DETROIT CHAPTER COMBINES BUSINESS WITH PLEASURE

On November 1 Detroit Chapter met at the home of member Jack Hasen in Windsor, Ontario, Canada. After a snappy business meeting Chairman James Quinn (that's him in the extreme upper right hand corner) asked for an adjournment and from that point on the members made whoopie. There was singing, cards, friendly arguments on radio and just good old-fashioned chumming. The above pictures are a few informal shots taken at the affair. Mrs. Hasen was out of the city. Our thanks to her for turning her home over to us and also for leaving her likeable husband Jack, to do the cooking, serving, and in every way play the part of a grand host.

## Detroit Chapter

(From page 27)

his year of office as President of the NRI Alumni Association—an honor shared by Earl Oliver who was President in 1943. Thereupon Jack Hasen, offered his spacious home in Windsor for the occasion and the date was set for November 1. This was a great get-together.

Mr. Menne and his assistant, Mr. H. L. Emerson, from Washington, were present at this meeting. Mr. Menne presented the gift of Detroit Chapter to Mr. Stephens with appropriate remarks. The gift consisted of a beautiful gold pen and pencil set, handsomely engraved and in addition, Mr. Stephens was presented with a wallet.

Mr. Menne also complimented Chairman Jim Quinn, Earl Oliver, Larry Upham, Bernard Hiller, John Stanish, Henry Rissi, Harold Chase, Val Guyton, W. L. Wayman, and others for their steadfast loyalty to our Alumni Association and willingness to go out of their way to make our local organization the successful chapter it is.

NRI men in the Detroit area are most welcome to meet with us. Any who wish to receive advance notices of meetings need only send the undersigned a post card giving name and address.

Val Guyton, Secretary  
13103 Stoepel Ave.  
Detroit 4, Mich.

## ALUMNI PRESIDENT VISITS WASHINGTON

Harry R. Stephens, President of the NRI Alumni Association, was in Washington on Oct. 7, 8 and 9, in his official capacity. Mrs. Stephens accompanied her very progressive husband on the trip which was made by airplane.

The Stephens had an exciting time. Arriving at NRI about 10 A. M. they were met by J. E. Smith, NRI President, and L. L. Menne, Executive Secretary of the NRI Alumni Association. Mr. Smith took the Stephens on a tour of the city, visiting most of the historical spots in the Nation's capitol. In the evening Mr. Stephens, Mr. Emerson and Mr. Menne went to Baltimore to attend a meeting of that Chapter. They received a very cordial reception. Our thanks, Chairman Rath-

bun, Vice President Gosnell, George Phillips, Larry Arthur and Percy Marsh for a splendid time at Baltimore Chapter.

Wednesday, the third and last day of our Alumni President's visit to headquarters was spent in conferring on Alumni matters, principally on the revision of our Constitution which needs streamlining. Our members will receive a letter early in 1947 with a copy of the proposed changes in the Constitution. They will be asked to vote to adopt or reject the proposed changes.

We enjoyed the company of these very wholesome people and we know they enjoyed their Washington visit. Come again, Mr. and Mrs. Stephens.



(Left) Harry R. Stephens and J. E. Smith at the entrance to the Institute (center) Mr. Stephens, Mrs. Stephens, Mr. Smith and Mr. Menne, pose for the scrap book, and again (right) Mr. Stephens and Mr. Menne under the powerful lights in the NRI laboratory.

**MERRY  
CHRISTMAS**

## Here And There Among Alumni Members

**HAPPY  
NEW  
YEAR**

Glenn A. Williams visited NRI while on vacation. Williams has been with the Acme Electric Corp., Cuba, N. Y., for quite some time, and is now foreman of their Radio department. He also mentioned that spare time Radio work has netted him over \$1,000 in the last eight months.

Frank Zimmer of New York Chapter has been confined to a hospital recovering from an operation. We hope that Frank will soon be able to be back on the job with more vim than ever.

Nicholas E. Grimaldi is now employed by two Chicago radio manufacturers. He acts as a buying representative, and also does assembly work. He sent us a "neat" circuit for a phono-amplifier of his own design.

It was good to learn the whereabouts of Alumnus J. W. Colvin. He has been with Bendix as a Field Service Engineer since 1942. When the Italian campaign was most intense, Colvin's duties were that of lone consultant on airborne communication equipment. He is now setting up maintenance facilities for personal plane and airline type Radios.

H. B. Beckholt, Chief Engineer of WSPA, "South Carolina's First Radio Station," and ever loyal to NRI, enrolled his wife for our Course. She was doing splendidly, but Mr. Beckholt says the stork has been hanging around, so the lessons will have to wait. Good luck, folks.

E. F. Nelson, 16 N. Kildaire Ave., Chicago, has received his first-class 'phone license. He says he is now interested in a broadcasting position.

A new Alumni member is Roy Jennings of Cumberland, Ky. He recently visited NRI and had a chat with Chief Instructor Dowie. Jennings is service manager for a large Cumberland Radio establishment.

Just received a letter from Dady S. Major, now Major Dady S. Major of the British Army. He was formerly a Radio Engineer with All-India Radio, and expects to return to this organization in April, '47. Our last letter to him, dated October 17, 1945, reached him only a short time ago.

A former Washingtonian, Bernard J. Flanders tells us he is now attending the University of Iowa, and also that he just acquired a lovely bride, formerly of Denver, Colo. Flanders served fifty-one months as a bomber pilot. Part-time

Radio servicing is going to help meet expenses while he finishes his education.

Mr. Bert Wappler, Chairman of New York Chapter, who designs and manufactures electronic-medical and industrial equipment, has just completed a shipment of a considerable number of generators and accessories to Westinghouse Electric Corp., International Division. Bert is already negotiating for another large order. All of this equipment is for export. His repair business is also thriving.

Howard E. Sanford has opened a larger store in Brooklyn, N. Y. The new business is strictly Radio and Television repair. Sanford uses a converted Army radar scope and signal generator for signal tracing, and is able to average 16 sets in a six-hour period.

Now attending school in Washington, Mr. K. Kengradomying (he prefers "Mr. Ken") is counting on starting a nice repair business when he returns to his home country of Siam. During Mr. Ken's service in the Siamese Army, he was loaned to the U. S. Navy. While visiting NRI a few weeks ago, he told of the thrilling experiences he had behind Jap lines as a secret communicator.

While flying back to Detroit from Washington, Alumni President Harry R. Stephens and his wife noticed a bronze plate on the door leading to the pilot quarters. The plate informed passengers that this was the plane used by President Roosevelt on his trip to Casablanca.

We are very sorry to learn that the mother of Lou Kunert was struck by an automobile. We hope Mrs. Kunert is feeling much better. Kunert is the very able secretary of our New York Chapter.

Graduate G. S. Corwin, Delaware, Ohio, writes that he is now in the field of Radio Communication Engineering. He specializes in Receiver and transmitter maintenance. Corwin served with the AAF.

One of our Chicago members, Mr. Leonard Park, tells us about his excellent position with a Chicago Division of RCA as a phaser-trouble shooter. Park mentioned that the servicing short cuts he learned from NRI are very useful in his work where speed and accuracy really count. He hopes to be working on high frequency equipment soon, which sounds even more complex.





Blacksburg, Virginia

Dear Mr. Smith:

I had intended to call on you this summer but so many things have required my attention here. I leave in two weeks for Sarasota, Florida, where I spend my winters, and quite right, I take my Hallicrafter SX28 with me.

I have enjoyed receiving your N. R. News. It is a fine pamphlet, entertaining as well as constructive.

I was thinking a few days ago that it is probably due to my taking your course that I made \$20,000 these past 5 years. My work was not all radio but the foundation laid down, plus some study of my own, placed me in a position to hold a 5-year job as electrical technician. Inter-office communication systems, time clocks, radio and mobile units—all work on radio principles. Best regards.

Sincerely,  
Oakey Martin.

— n r i —

Have you seen the announcement of the new NRI Professional Tube Tester on page 13?

Page Thirty-two

# NATIONAL RADIO NEWS

FROM N.R.I. TRAINING HEADQUARTERS

Vol. 12 Dec., 1946-Jan., 1947 No. 6

Published every other month in the interest of the students and Alumni Association of the

NATIONAL RADIO INSTITUTE  
Washington 9, D. C.

The Official Organ of the N. R. I. Alumni Association  
Editorial and Business Office, 16th & You Sts., N. W.,  
Washington, D. C.

L. L. MENNE, EDITOR  
J. B. STRAUGHN, TECHNICAL EDITOR

NATIONAL RADIO NEWS accepts no paid advertising. Articles referring to products of manufacturers, wholesalers, etc., are included for readers' information only, and we assume no responsibility for these companies or their products.

## Index

Article	Page
Editorial .....	2
Starting A Spare Time Service Business ..	3
How to Get Along With Others .....	12
NRI Professional Radio Tube Tester .....	13
Recent Additions to the NRI Staff .....	14
News of the Radio World .....	15
How Circuit Diagrams are Used in Servicing 16	
Service Sheet—Garod 5A2 .....	23
Alumni Election News .....	25
Chapter News .....	26
Election Ballot .....	27
Here and There Among Alumni Members ..	31

Printed in U.S.A.